

ViewSonic®

PJ258D

ViewDock DLP Projector



- User Guide
- Guide de l'utilisateur
- Bedienungsanleitung
- Guía del usuario
- Guida dell'utente
- Guia do usuário
- Användarhandbok
- Käyttöopas
- Руководство пользователя
- 使用手冊 (繁體)
- 使用手冊 (简体)

Model No. : VS11542

Compliance Information

FCC Statement

This device complies with part 15 of FCC Rules. Operation is subject to the following two conditions: (1) this device may not cause harmful interference, and (2) this device must accept any interference received, including interference that may cause undesired operation.

This equipment has been tested and found to comply with the limits for a Class B digital device, pursuant to part 15 of the FCC Rules. These limits are designed to provide reasonable protection against harmful interference in a residential installation. This equipment generates, uses, and can radiate radio frequency energy, and if not installed and used in accordance with the instructions, may cause harmful interference to radio communications. However, there is no guarantee that interference will not occur in a particular installation. If this equipment does cause harmful interference to radio or television reception, which can be determined by turning the equipment off and on, the user is encouraged to try to correct the interference by one or more of the following measures:

- Reorient or relocate the receiving antenna.
- Increase the separation between the equipment and receiver.
- Connect the equipment into an outlet on a circuit different from that to which the receiver is connected.
- Consult the dealer or an experienced radio/TV technician for help.

Warning: You are cautioned that changes or modifications not expressly approved by the party responsible for compliance could void your authority to operate the equipment.

For Canada

- This Class B digital apparatus complies with Canadian ICES-003.
- Cet appareil numérique de la classe B est conforme à la norme NMB-003 du Canada.

CE Conformity for European Countries

 The device complies with the requirements of the EEC directive 89/336/EEC as amended by 92/31/EEC and 93/68/EEC Art.5 with regard to “Electromagnetic compatibility”, and 73/23/EEC as amended by 93/68/EEC Art.13 with regard to “Safety.”

Following information is only for EU-member states:

The mark shown to the right is in compliance with the Waste Electrical and Electronic Equipment Directive 2002/96/EC (WEEE).

The mark indicates the requirement NOT to dispose the equipment as unsorted municipal waste, but use the return and collection systems according to local law.



Important Safety Instructions

1. Read these instructions.
2. Keep these instructions.
3. Heed all warnings.
4. Follow all instructions.
5. Do not use this unit near water.
6. Clean with a soft, dry cloth. If still not clean, see “Cleaning the Display” in this guide for further instructions.
7. Do not block any ventilation openings. Install the unit in accordance with the manufacturer’s instructions.
8. Do not install near any heat sources such as radiators, heat registers, stoves, or other devices (including amplifiers) that produce heat.
9. Do not defeat the safety purpose of the polarized or grounding-type plug. A polarized plug has two blades with one wider than the other. A grounding type plug has two blades and a third grounding prong. The wide blade and the third prong are provided for your safety. If the provided plug does not fit into your outlet, consult an electrician for replacement of the obsolete outlet.
10. Protect the power cord from being walked on or pinched particularly at plugs. Convenience receptacles and the point where they exit from the unit. Be sure that the power outlet is located near the unit so that it is easily accessible.
11. Only use attachments/accessories specified by the manufacturer.
12.  Use only with the cart, stand, tripod, bracket, or table specified by the manufacturer, or sold with the unit. When a cart is used, use caution when moving the cart/unit combination to avoid injury from tipping over.
13. Unplug this unit when unused for long periods of time.
14. Refer all servicing to qualified service personnel. Servicing is required when the unit has been damaged in any way, such as: if the power-supply cord or plug is damaged, if liquid is spilled onto or objects fall into the unit, if the unit is exposed to rain or moisture, or if the unit does not operate normally or has been dropped.

Declaration of RoHS Compliance

This product has been designed and manufactured in compliance with Directive 2002/95/EC of the European Parliament and the Council on restriction of the use of certain hazardous substances in electrical and electronic equipment (RoHS Directive) and is deemed to comply with the maximum concentration values issued by the European Technical Adaptation Committee (TAC) as shown below:

Substance	Proposed Maximum Concentration	Actual Concentration
Lead (Pb)	0.1%	< 0.1%
Mercury (Hg)	0.1%	< 0.1%
Cadmium (Cd)	0.01%	< 0.01%
Hexavalent Chromium (Cr ⁶⁺)	0.1%	< 0.1%
Polybrominated biphenyls (PBB)	0.1%	< 0.1%
Polybrominated diphenyl ethers (PBDE)	0.1%	< 0.1%

Certain components of products as stated above are exempted under the Annex of the RoHS Directives as noted below:

Examples of exempted components are:

1. Mercury in compact fluorescent lamps not exceeding 5 mg per lamp and in other lamps not specifically mentioned in the Annex of RoHS Directive.
2. Lead in glass of cathode ray tubes, electronic components, fluorescent tubes, and electronic ceramic parts (e.g. piezoelectronic devices).
3. Lead in high temperature type solders (i.e. lead-based alloys containing 85% by weight or more lead).
4. Lead as an alloying element in steel containing up to 0.35% lead by weight, aluminium containing up to 0.4% lead by weight and as a copper alloy containing up to 4% lead by weight.

Copyright Information

Copyright © ViewSonic® Corporation, 2007. All rights reserved.

Macintosh and Power Macintosh are registered trademarks of Apple Computer, Inc.

Microsoft, Windows, Windows NT, and the Windows logo are registered trademarks of Microsoft Corporation in the United States and other countries.

ViewSonic, the three birds logo, OnView, ViewMatch, and ViewMeter are registered trademarks of ViewSonic Corporation.

VESA is a registered trademark of the Video Electronics Standards Association. DPMS and DDC are trademarks of VESA.

PS/2, VGA and XGA are registered trademarks of International Business Machines Corporation.

Disclaimer: ViewSonic Corporation shall not be liable for technical or editorial errors or omissions contained herein; nor for incidental or consequential damages resulting from furnishing this material, or the performance or use of this product.

In the interest of continuing product improvement, ViewSonic Corporation reserves the right to change product specifications without notice. Information in this document may change without notice.

No part of this document may be copied, reproduced, or transmitted by any means, for any purpose without prior written permission from ViewSonic Corporation.

Product Registration

To meet your future needs, and to receive any additional product information as it becomes available, please register your product on the Internet at: www.viewsonic.com. The ViewSonic® Wizard CD-ROM also provides an opportunity for you to print the registration form, which you may mail or fax to ViewSonic.

For Your Records

Product Name:	PJ258D ViewDock DLP Projector
Model Number:	VS11542
Document Number:	PJ258D_UG_ENG Rev. 1C 06-07-07
Serial Number:	_____
Purchase Date:	_____



The lamp in this product contains mercury.

Please dispose of in accordance with local, state or federal laws.

CONTENTS

Introduction.....	1
Projector Features.....	1
Notes on AC Power Cord	1
Package Contents.....	2
Projector Overview.....	3
Using the Product.....	5
Control Panel.....	5
Connection Ports.....	6
Remote Control.....	7
Installing the Batteries.....	8
Remote Control Operation.....	9
Installation	10
Connecting the Projector	10
Powering On/Off the Projector.....	11
Adjusting the Projector.....	12
Menu Operation	14
ViewDock projection with iPod® with Video.....	17
Audio setting with iPod	18
Maintenance.....	19
Cleaning the Lens.....	19
Cleaning the Projector Housing.....	19
Replacing the Lamp.....	20
Specifications	22
Appendix	23
LED Indicator Messages	23
Compatibility Modes.....	24
Troubleshooting.....	25
Other Information	26
Customer Support.....	26
Limited Warranty.....	27

Introduction

Projector Features

The projector integrates high-performance optical engine projection and a user-friendly design to deliver high reliability and ease of use.

The projector offers the following features:

- ViewDock multimedia base with iPod for video dock.
- iPod remote control function
- Single chip 0.55" Texas Instruments DLP® technology
- XGA (1024 x 768 pixels)
- Auto image re-sizing (Auto-Sync.) to 1024 x 768 full screen with scaling compression compatibility for VGA, SVGA, XGA and SXGA*
- Compatibility with Macintosh® computers
- Compatibility with NTSC, PAL, SECAM, and HDTV
- D-Sub 15-pin terminal for analog video connectivity
- User-friendly, multi-language on-screen display (OSD)
- Advanced electronic keystone correction

NOTE

* *means compressed.*

Notes on AC Power Cord

AC Power Cord must meet requirement of country where you use a projector. Confirm an AC plug type with graphics below and proper AC Power Cord must be used. If supplied AC Power Cord does not match your AC outlet, contact your sales dealer. This projector is equipped with a grounding type AC line plug. Make sure that your outlet fits the plug. Do not defeat the safety purpose of this grounding type plug. We highly recommend using a video source device also equipped with a grounding type AC line plug to prevent from signal interference due to voltage fluctuation.

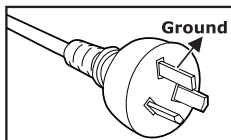

For Australia and
Mainland China

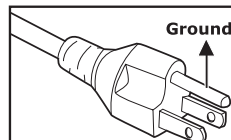

For the U.S.A. and Canada

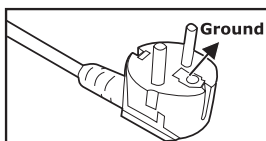

For Continental Europe

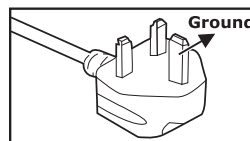

For the U.K.

Package Contents

When you unpack the projector, make sure you have all these components:



Projector with Lens Cap

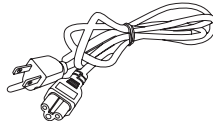

AC Power Cord

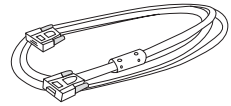

VGA Cable
(D-Sub to D-Sub)



S-Video Cable

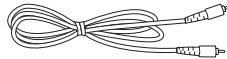

Composite Video Cable

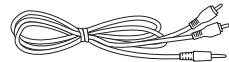

Audio Cable



Remote Control (IR)



CD Wizard



Adapter
(D-Sub to Component)

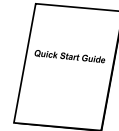

Quick Start Guide

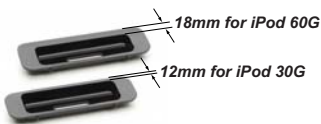

* iPod cradle x 2 pcs



AAA size batteries
for remote control



Projector Carrying Case

NOTE

- **Save the original shipping carton and packing material; they will come in handy if you ever to ship your unit. For maximum protection, repack your unit as it was originally packed at the factory.**
- **Accessories and components may vary by retailer and region.**
- * **iPod cradle is a part for helping to fix the iPod.**

Projector Overview

Front View



- | | |
|--------------------|-----------------------------------|
| 1. iPod connector | 6. Lens cap strap |
| 2. Zoom rod | 7. Focus ring |
| 3. Projection lens | 8. Front IR remote control sensor |
| 4. Elevator button | 9. Ventilation holes |
| 5. Lens cap | 10. AC power socket |

Rear View

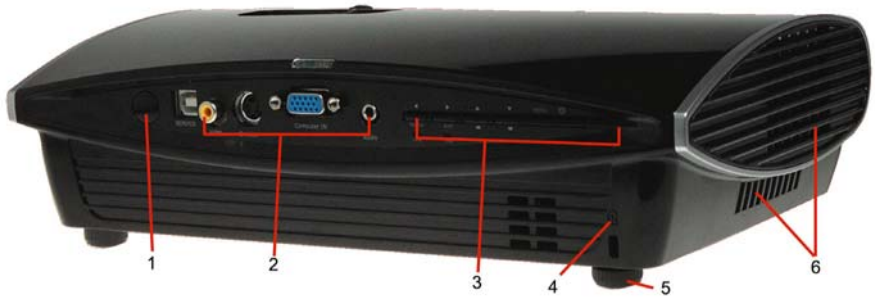

1. Rear IR remote control sensor
2. Connection ports
3. Control panel
4. Kensington lock
5. Tilt-adjustment foot
6. Ventilation holes

Bottom View

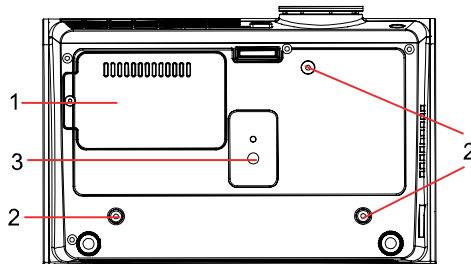

1. Lamp cover
2. Ceiling mount
3. Tripod mount

NOTE

- ***This projector can be used with a ceiling mount for support. The ceiling mount is not included in the package.***
- ***When the projector is ceiling mounted upside down, do not dock the iPod.***

Using the Product



Control Panel

LED



1. **Power LED indicator**
Refer to “LED Indicator Messages”.
2. **Lamp** (Lamp LED indicator)
Refer to “LED Indicator Messages”.
3. **Temp.** (Temperature LED indicator)
Refer to “LED Indicator Messages”.

Button Function

4. ◀ / ▲ / ▼ / ▶
Use four directional buttons to select items or make adjustments to your selection.
5. **MENU**
Opens the on-screen menu or acts on the selected menu item.
6. 
Turns the projector on or off.
7. **Source**
Manually selects an input source.
8. **Auto**
Resynchronizes the projector to the input signal from a computer.
9.  /  (Keystone)
Adjusts image distortion caused by tilting the projector.

Connection Ports

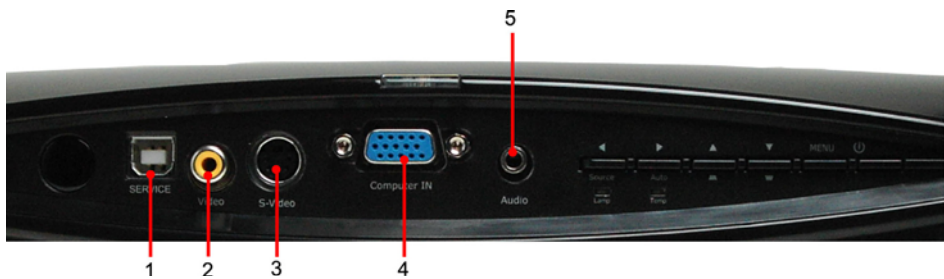

1. **SERVICE**

This connector is for firmware update.

2. **Video**

Connects composite video output from video equipment to this jack.

3. **S-Video**

Connects S-Video output from video from video equipment to this jack.



4. **Computer IN**

Connects image input signal (analog) to this jack.

5. **Audio**

Connects an audio output from video equipment to this jack when **Audio > Line out** is set to **ON** or **OFF**, for iPod function use only.

Remote Control

- 1.  Power**
Turns the projector on or off.
- 2. Four directional buttons**
Use four directional buttons to select items or make adjustments to your selection.
- 3. MENU**
Opens the on-screen menu or acts on the selected menu item.
- 4. Laser**
Aim the remote at the viewing screen, press and hold this button to activate the Laser light pointer.
- 5. **
iPod remote control function (backward/play and pause/forward)
- 6. Resync**
Resynchronizes the projector to the input signal from a computer.
- 7. Hide**
Hides the screen and mutes the sound. Press again to cancel the Hide function.
- 8. 4:3/16:9**
Press the 4:3/16:9 to switch the image aspect ratio from 4:3 to 16:9.
- 9. Source**
Manually selects an input source.
- 10. Volume - / Volume +**
iPod remote control function (volume up and down)
- 11. Freeze**
Press "Freeze" to pause the screen image. Press again to cancel the Freeze function.

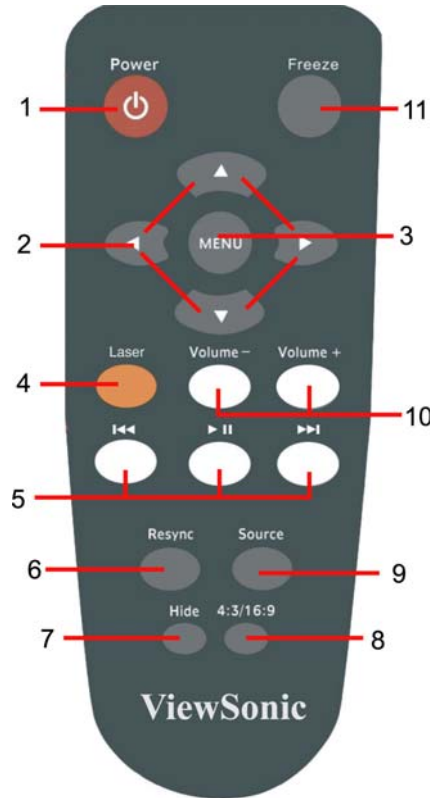

Installing the Batteries

1. Open the battery cover in the direction shown.

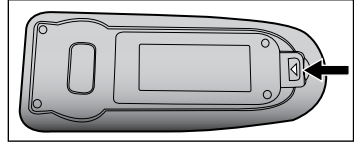

2. Install batteries as indicated by the diagram inside the compartment.

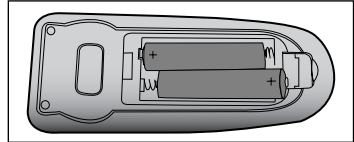

3. Close the battery cover into position.

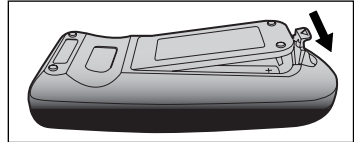

NOTE

- **Keep the batteries out of the reach of children. There is a danger of death by accidentally swallowing the battery.**
- **Remove batteries from remote control when not using for extended periods.**
- **Do not dispose of the used battery along with household waste. Dispose of used batteries according to local regulations.**
- **Danger of explosion may happen if batteries are incorrectly replaced. Replace all the batteries with new ones.**

Remote Control Operation

Point the remote control at the infrared remote sensor and press a button.

- Operating the projector from the front



- Operating the projector from the rear

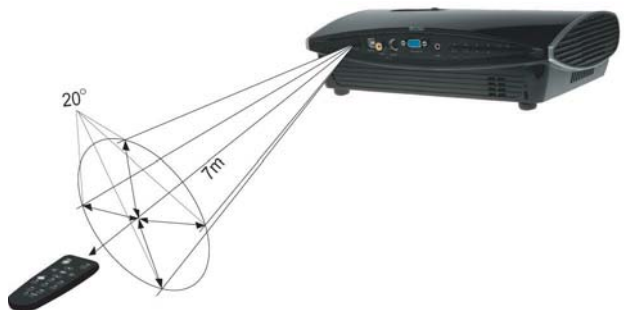

NOTE

- ***Do not point the Laser light pointer directly to the people's eyes (especially small children). There is a danger of injury to the eyes.***
- ***The remote control may not operate when there is sunlight or other strong light such as a fluorescent lamp shining on the remote sensor.***
- ***Operate the remote control from a position where the remote sensor is visible.***
- ***Do not drop the remote control or jolt it.***
- ***Keep the remote control out of locations with excessively high temperature or humidity.***
- ***Do not get water on the remote control or place wet objects on it.***

Installation

Connecting the Projector

1. Composite Video Cable
2. S-Video Cable
3. VGA Cable (D-Sub to D-Sub)
4. Audio Cable
5. Adapter (D-Sub to Component)

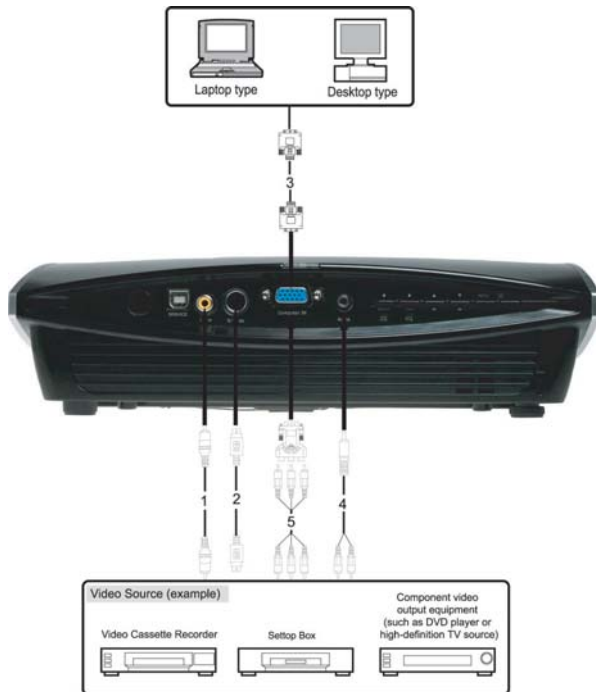

NOTE

- **When Audio > Auto Select is set to Line Out, the speaker output is muted.**
- **When connecting cable, power cords of both a projector and external equipment should be disconnected from AC outlet.**
- **The figure above is a sample connection. This does not mean that all of these devices can or must be connected simultaneously.**
- **The cables that come with the projector may differ from the above illustration. The included cables are based on actual shipment delivery.**

Powering On/Off the Projector



Powering On the projector:

1. Remove the projector lens cap.
2. Complete the AC power cord and peripheral signal cable(s) connections.
3. Press  button on the projector.
The projector takes a minute or so to warm up.
4. Turn on your source (computer, notebook, DVD, etc.). The projector automatically detects your source.
 - If you are connecting multiple sources to the projector simultaneously, press **Source** button.

Warning:

- Remove the lens cap first before powering on.
- Never look into the lens when the lamp is on. This can damage your eyes. It is especially important that children are not allowed to look into the lens.

Powering Off the Projector:

1. Press  button to turn off the projector lamp. You will see a message “Press Power Button to Turn Off Projector. Projector must cool down for 90 seconds before unplugging or restarting.” appear on the screen.
2. Press  button again to confirm.
 - The cooling fans continue to operate for cooling cycle.
 - When the Power LED begins flashing, the projector has entered stand-by mode.
 - If you want to turn the projector back on, you must wait until the projector has completed the cooling cycle and has entered stand-by mode. Once in stand-by mode, simply press  button to restart the projector.
3. Disconnect the AC power cord from the electrical outlet and the projector.
4. Do not turn on the projector immediately following a power off procedure.

Warning:

- 90 seconds for capacitor recharge before unplugging function.

Adjusting the Projector

Adjusting the Projector Height

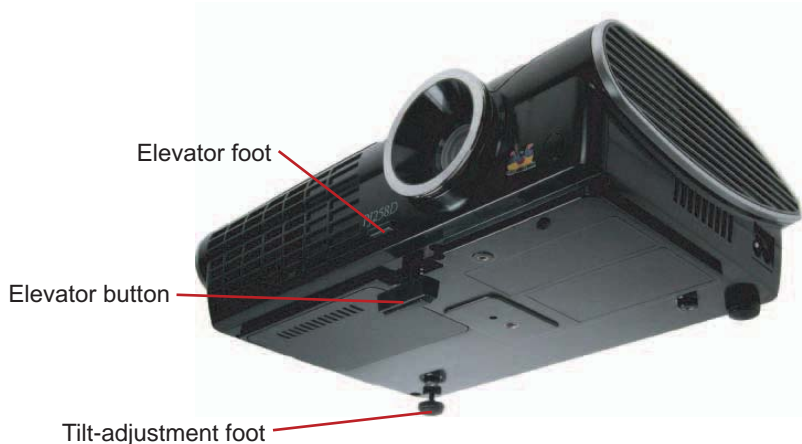

The projector is equipped with an elevator foot and a tilt-adjustment foot to adjust the image height.

To raise or lower the image:

1. To raise or lower the image, press the elevator button and raise or lower the front of the projector. Release the button to lock the adjustment.
2. To level the image on the screen, turn the tilt-adjustment foot to fine-tune the height.

NOTE

- ***To avoid damaging the projector, make sure that the elevator foot and tilt-adjustment feet are fully retracted before placing the projector in its carrying case.***

Adjusting the Projector Zoom and Focus

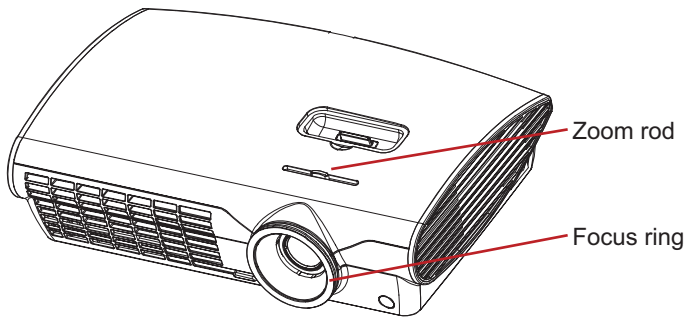

1. Focus the image by rotating the focus ring. A still image is recommended for focusing.
2. Adjust the image by sliding the zoom rod.

Adjusting Projection Image Size

Refer to the graphic and table below to determine the screen size and projection distance.

Projection Distance (meters)	Screen size (inches)	
	Wide	Tele
1.6	41	34
2	51	43
3	77	65
5	128	108
10	256	217
12	307	260

NOTE

- **Position the projector in a horizontal position; other positions can cause heat build-up and damage to the projector.**
- **Make sure the heat ventilation holes are not blocked.**
- **Do not use the projector in a smoky environment. Smoke residue may cause build-up on critical parts (i.e. DMD, lens assembly, etc.)**

Menu Operation

The projector has multilingual on-screen display menus that allow you to make image adjustments and change a variety of settings.

How to operate

1. Press **MENU** to open the OSD menu.
2. When OSD is displayed, use ▲ / ▼ to select any feature in the main menu.
After selecting the desired main menu feature, press ► to enter sub-menu for feature setting.
3. Adjust the settings with ◀ / ▶ .
4. Press **MENU** button, the screen will return to the main menu.
5. To exit OSD, press **MENU** button again. The OSD menu will close and the projector will automatically save the new settings.

All Images (Computer / Video Mode)

Brightness

Brightens or darkens the image.

Contrast

Sets the difference between light and dark areas.

Color Setting

Press ► to enter Color Temperature sub-menu and adjust the color temperature. At higher temperature the screen looks colder; at lower temperature, the screen looks warmer. If you select "User", "Red", "Green" and "Blue" can be adjusted.

Keystone

Adjusts image distortion caused by tilting the projector.

Aspect Ratio

Selects how the picture fits on the screen:

- 1:1 : Keep the image with original width-height ratio and maximize the image to fit native horizontal or vertical pixels.
- 4:3 : The input source will be scaled to fit the projection screen.
- 16:9 : The input source will be scaled to fit the width of the screen.

Video Mode

There are many factory presets optimized for various types of images.

- PC : For computer or notebook.
- Movie : For home theater.
- sRGB : For PC standard color.
- User : Memorize user's settings.

White Intensity

Increases the brightness of white areas.

Degamma

Effects the represent of dark scenery. With greater gamma value, dark scenery will look brighter.

Computer Image (Computer Mode)

Frequency

Adjusts the timing of the projector relative to the computer.

Tracking

Adjusts the phase of the projector relative to the computer.

Hor. Position (Horizontal Position)

Adjusts the image left or right within the projection area.

Ver. Position (Vertical Position)

Adjusts the image up or down within the projection area.

Video Image (Video Mode)

Saturation

Adjusts the intensity of colors.

Sharpness

Sharpens or softens the image.

Tint

Shifts colors toward red or green.

Audio (Computer / Video Mode)

Volume

Adjusts the loudness of the projector's audio.

Mute

Temporarily turns off the projector's audio.

Line Out

Selects Line Out ON or OFF. (For iPod function only)

Management (Computer / Video Mode)

Menu Location

Choose the menu location on the display screen.

Projection Mode

Adjusts the picture to match the orientation of the projector: upright or upside-down, in front of or behind the screen. Inverts or reverses the image accordingly.

Signal Type

Specifies the signal source that you wish to project.

- YPbPr: For composite video cable.
- RGB: For VGA cable.
- YCbCr: For S-Video cable.

Lamp Hour

Displays the lamp's elapsed operating time (in hours).

Power Saving

If no operation is performed for a specific period of time, the power to the projector is automatically turned off. This feature is useful to reduce battery wear.

Auto Source

Automatically scans the input source.

Lamp Power

Selects lamp power. (Normal/ECO1/ECO2/Daylight mode)

High Altitude

Turning on High Altitude mode operates the fans at full speed continuously to allow for proper high altitude cooling of the projector.

OSD Timeout

Duration OSD menu stays active (at idle state by second).

Language (Computer / Video Mode)

Selects the language used by the on-screen menu.

Factory Reset (Computer / Video Mode)

Restores all menu settings to factory default settings.

ViewDock projection with iPod® with Video



Multimedia base features iPod dock, which brings your music, videos and photos together.

1. Turn on the projector.
2. Setup the iPod cradle on the iPod connector.
3. Dock your iPod to fit the iPod connector. Please set the video setting of your iPod with video to “TV out-YES”, so the iPod will output a signal to the projector.
Please refer to your iPod user manual for further instruction.
4. ViewDock base features iPod dock to project videos and photos.
5. Control through projector remote control.

NOTE

- ***Do not move or transport the projector while the iPod is docked.***
- ***When the projector is ceiling mounted upside down, do not dock the iPod.***
- ***In order to project an image from the iPod with video, the video setting of the iPod must be set to “TV out-YES”. Please refer to your iPod user manual for further instruction.***
- ***For best video performance, please set iPod video output to PAL.***
- ***The unplug and go function will interrupt the power on operation when the shut down process has not yet completed, after the shut down process has completed, please push the power button, the unit will turn on again.***

Audio setting with iPod

1. Press the Menu button on the remote control to enter the OSD menu.
2. Select Audio item and then enter the Audio setting.
3. To use the internal speaker, set the projector as follows:



4. To use the external speakers, set the projector as follows:



Maintenance

The projector needs proper maintenance. You should keep the lens clean as dust, dirt or spots will project on the screen and diminish image quality. If any other parts need replacing, contact your dealer or qualified service personnel. When cleaning any part of the projector, always switch off and unplug the projector first.

Warning:

Never open any of the covers on the projector. Dangerous electrical voltages inside the projector can cause severe injury. Do not attempt to service this product yourself. Refer all servicing to qualified service personnel.

Cleaning the Lens

Gently wipe the lens with lens cleaning paper. Do not touch the lens with your hands.

Cleaning the Projector Housing

Gently wipe with a soft cloth. If dirt and stains are not easily removed, use a soft cloth dampened with water, or water and neutral detergent, and wipe dry with a soft, dry cloth.

NOTE

- **Turn off the projector and remove the AC power cord from the power outlet before beginning maintenance work.**
- **Make sure the lens is cool before cleaning.**
- **Do not use detergents or chemicals other than those noted above. Do not use benzene or thinners.**
- **Do not use chemical sprays.**
- **Use a soft cloth or lens paper only.**

Replacing the Lamp

As the projector operates over time, the brightness of the projector lamp gradually decreases and the lamp becomes more susceptible to breakage. You can install a new lamp at any time to bring the projector up to factory-fresh brightness. We recommend replacing the lamp if a warning message is displayed.

NOTE

- ***The lamp becomes high temperature after turning off the projector with the power button. If you touch the lamp, you may scald your finger. When you replace the lamp, wait for at least 45 minutes for the lamp to cool down.***
- ***Do not touch the lamp glass at any time. The lamp may explode due to improper handling, including the touching of the lamp glass.***
- ***Lamp lifetime may differ from lamp to lamp and according to the environment of use. There is no guarantee of the same lifetime for each lamp. Some lamps may fail or terminate their lifetime in a shorter period of time than other similar lamps.***
- ***A lamp may explode as a result of vibration, shock or degradation as a result of hours of use as its lifetime draws to an end. Risk of explosion may differ according to the environment or conditions in which the projector and lamp are being used.***
- ***Wear protective gloves and eyeglasses when fixing or detaching the lamp.***
- ***Faster on-off-cycles will damage the lamp and reduce lamp life. Wait at least for 5 minutes to turn off the projector after powering on.***
- ***Do not operate the lamp in proximity to paper, cloth, or other combustible material nor cover it with such materials. Otherwise it could cause a fire.***
- ***Do not operate the lamp in an atmosphere containing an inflammable substance, such as thinner. Otherwise it could cause a fire or explosion.***
- ***Thoroughly ventilate the area or the room when operating the lamp in an oxygen atmosphere (in the air). If ozone is inhaled, it could cause headaches, nausea, dizziness, etc.***
- ***The inorganic mercury is involved in the lamp. If the lamp bursts, the mercury inside the lamp will go out of the projector. Leave the area immediately if the lamp shatters while being operated and ventilate the area for at least 30 minutes in order to avoid the inhalation of mercury fumes. Otherwise it could be harmful to user's health.***

1. Turn off the projector.
2. If the projector is installed in a ceiling mount, remove it from the mount.
3. Unplug the power cord.
4. Loosen the screw in the lamp cover and remove the cover.
5. Remove the screws from the lamp module, raise the handle, and lift out the module.
6. Insert the new lamp module into the projector and tighten the screws.
7. Replace the lamp cover and tighten the screw.
8. Turn on the projector. If the lamp does not turn on after the warm-up period, try reinstalling the lamp.

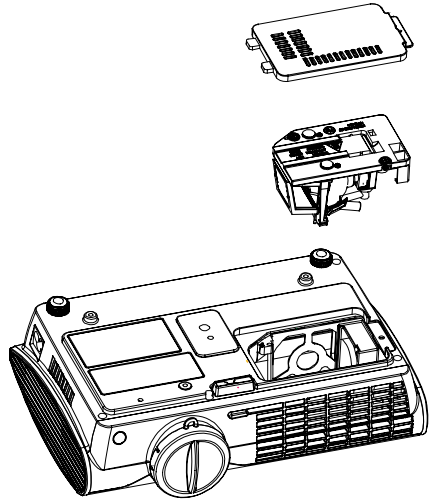

NOTE

- **Dispose of the used lamp according to local regulations.**
- **Ensure that screws are tightened properly. Screws not tightened fully may result in injury or accidents.**
- **Since the lamp is made of glass, do not drop the unit and do not scratch the glass.**
- **Do not reuse the old lamp. This could cause the lamp to explode.**
- **Be sure to turn off the projector and unplug the AC power cord before replacing the lamp.**

Specifications

Display Type	Single 0.55" DLP panel
Resolution (Pixels)	XGA (1024 × 768)
Brightness Lens	Manual Zoom (1.2X)
Aspect Ratio	Auto, 16:9, 4:3
Lamp	200W
Projection Type	Front, Rear, Ceiling
Input / Source	D-Sub 15 pin, S-video, composite video, audio input/output, USB port, iPod video
Video Compatibility	NTSC4.43 PAL-60, M, N, B, D, G, H SECAM
Scanning Frequency Horizontal Frequency Vertical Frequency	31 - 79 KHz 50 - 85 Hz
iPod Connectivity	Battery charger Video output (as S-Video format) Audio output (share system speaker or audio-in connector) Control through projector remote control (play/pause/forward/ backward/volume +/-volume-)
OSD Language	Multi-language
Environment	Operating: Temperature: 5°C to 35 °C Humidity: 85% maximum Storage: Temperature: -20°C to 60 °C Humidity: 85% maximum High Altitude mode
Power Requirement	AC 100 – 220V, 50 / 60 Hz
Power Consumption	230W
Dimension	286 × 188 × 86 mm
Weight	1.8 kg (3.9lb)

Note: Design and Specifications are subject to change without prior notice.

Appendix

LED Indicator Messages

	LED Indication	Power LED	Lamp LED	Temp. LED
Stand-by		Blue flashing	Blank	Blank
Turn on	Warm up 1	Blue Solid	Flash once	Flash once
	Warm up 2 (normal)	Blue Solid	Blank	Blank
Normal operation	normal	Blue Solid	Blank	Blank
	lamp life warning	Blue Solid	Red flashing	Blank
Cooling	normal	Blue Solid	Red Solid	Red Solid
	temp abnormal	Blue Solid	Red Solid	Red flashing
	temp abnormal	Blue Solid	Red flashing	Red Solid

Compatibility Modes

Computer:

Compatibility	Resolution	H-Sync [KHz]	V-Sync [Hz]
VGA	640x480	37.86	72.8
	640x480	37.5	75.0
	640x480	43.2	85.0
	720x400	31.5	70.0
	720x400	37.9	85.0
SVGA	800x600	35.1	56.2
	800x600	37.8	60.3
	800x600	48.0	72.1
	800x600	46.8	75.0
XGA	1024x768	48.3	60.0
	1024x768	56.4	70.0
	1024x768	60.0	75.0
	1024x768	68.8	84.9
SXGA	1280x1024	63.9	60.0
	1280x1024	79.9	75.0
	1024x768	48.3	60.0
	1152x870	68.6	75.0
	1152x864	67.5	75.0
MAC 16"	832x624	49.7	74.5

Video:

Signal	Horizontal Frequency (kHz)	Vertical Frequency (Hz)
480p	31.5 kHz	60 Hz
720p	45 kHz	60 Hz
1080i	33.7 kHz	30 Hz

Troubleshooting

Refer to the symptoms and measures listed below before sending the projector for repairs. If the problem persists, contact your local reseller or service center. Please refer to “Indicator Messages” as well.

Start-up problems

If no lights or sounds turn on:

- Be sure that the power cord is securely connected to the projector and the other end is plugged into an outlet with power.
- Be sure the power switch is turned on.
- Press the power button again.
- Unplug the power cord and wait for a short while, then plug it in and press the power button again.
- The unplug and go function will interrupt the power on operation when the shut down process has not yet completed, after the shut down process has completed, please push the power button, the unit will turn on again.

Image problems

If the searching source is displayed

- Press the **Source** button on the projector or the remote control one or more times to select another active input source.
- Be sure the external source is turned on and connected.
- For a computer connection, ensure your notebook computer’s external video port is turned on. Refer to the computer manual.

If the image is out of focus:

- Be sure the lens cover is open.
- While displaying the on-screen menu, adjust the focus ring. (The image size should not change; if it does, you are adjusting the zoom, not the focus.)
- Check the projection lens to see if it needs cleaning.

If the image is flickering or unstable for a computer connection:

- Press the **Resync** button.
- Press **MENU**, go to **Computer Image** and adjust **Frequency** or **Tracking**.

Remote control problems

If the remote control does not operate:

- Be sure nothing is blocking the remote control receiver on the front or back of the projector. Use the remote control within the effective range.
- Aim the remote control at the screen or at the front or back of the projector.
- Move the remote control so it is more directly in front of or behind the projector and not as far to the side.

Other Information

Customer Support

For technical support or product service, see the table below or contact your reseller.

Note : You will need the product serial number.

Country/Region	Web Site	T=Telephone F=Fax	E-mail
Australia/New Zealand	www.viewsonic.com.au	AUS=1800 880 818 NZ=0800 008 822	service@au.viewsonic.com
Canada	www.viewsonic.com	T= 1-866-463-4775 F= 1-909-468-5814	service.ca@viewsonic.com
Europe/Middle East/Baltic countries/North Africa	www.viewsoniceurope.com	Contact your reseller	
Hong Kong	www.hk.viewsonic.com	T= 852 3102 2900	service@hk.viewsonic.com
India	www.in.viewsonic.com	T= 1800 11 9999	service@in.viewsonic.com
Korea	www.kr.viewsonic.com	T= 080 265 9080	service@kr.viewsonic.com
Latin America (Argentina)	www.viewsonic.com/la/	T= 0800-666-0098 F= 1-909-444-5655	soporte@viewsonic.com
Latin America (Brazil)	www.viewsonic.com/la/	T= 0800-891-1829 F= 1-909-444-5655	soporte@viewsonic.com
Latin America (Chile)	www.viewsonic.com/la/	T= 800-440303 F= 1-909-444-5655	soporte@viewsonic.com
Latin America (Columbia)	www.viewsonic.com/la/	T= 01800-9-156588 F= 1-909-444-5655	soporte@viewsonic.com
Latin America (Mexico)	www.viewsonic.com/la/	T= 001-866-823-2004 F= 1-909-444-5655	soporte@viewsonic.com
Latin America (Peru)	www.viewsonic.com/la/	T= 0800-53311 F= 1-909-444-5655	soporte@viewsonic.com
Macau	www.hk.viewsonic.com	T= 853 700 303	service@hk.viewsonic.com
Puerto Rico & Virgin Islands	www.viewsonic.com	T= 1-800-688-6688 (English) T= 1-866-379-1304 (Spanish) F= 1-909-468-1202	service.us@viewsonic.com soporte@viewsonic.com
Singapore/Malaysia/Thailand	www.ap.viewsonic.com	T= 65 64616044	service@sg.viewsonic.com
South Africa	www.viewsoniceurope.com	www.viewsoniceurope.com/uk/Support/Calldesk.htm	
United Kingdom	www.viewsoniceurope.com/uk/	www.viewsoniceurope.com/uk/Support/Calldesk.htm	
United States	www.viewsonic.com	T= 1-800-688-6688 F= 1-909-468-1202	service.us@viewsonic.com

Limited Warranty

VIEWSONIC® PROJECTOR

What the warranty covers:

ViewSonic warrants its products to be free from defects in material and workmanship, under normal use, during the warranty period. If a product proves to be defective in material or workmanship during the warranty period, ViewSonic will, at its sole option, repair or replace the product with a like product. Replacement product or parts may include remanufactured or refurbished parts or components.

How long the warranty is effective:

North and South America: 3 years for all parts excluding the lamp, 3 years for labor, 1 year for the original lamp from the date of the first consumer purchase.

Europe: 3 years for all parts excluding the lamp, 3 years for labor, 1 year for the original lamp from the date of the first consumer purchase.

Other regions or countries: Please check with your local dealer or local ViewSonic office for the warranty information.

Lamp warranty subject to terms and conditions, verification and approval. Applies to manufacturer's installed lamp only.

All accessory lamps purchased separately are warranted for 90 days.

Who the warranty protects:

This warranty is valid only for the first consumer purchaser.

What the warranty does not cover:

1. Any product on which the serial number has been defaced, modified or removed.
2. Damage, deterioration or malfunction resulting from:
 - a. Accident, misuse, neglect, fire, water, lightning, or other acts of nature, unauthorized product modification, or failure to follow instructions supplied with the product.
 - b. Repair or attempted repair by anyone not authorized by ViewSonic.
 - c. Any damage of the product due to shipment.
 - d. Removal or installation of the product.
 - e. Causes external to the product, such as electric power fluctuations or failure.
 - f. Use of supplies or parts not meeting ViewSonic's specifications.
 - g. Normal wear and tear.
 - h. Any other cause which does not relate to a product defect.
3. Any product exhibiting a condition commonly known as "image burn-in" which results when a static image is displayed on the product for an extended period of time.
4. Removal, installation, and set-up service charges.

How to get service:

1. For information about receiving service under warranty, contact ViewSonic Customer Support (please refer to "Customer Support" page). You will need to provide your product's serial number.
2. To obtain warranted service, you will be required to provide (a) the original dated sales slip, (b) your name, (c) your address, (d) a description of the problem, and (e) the serial number of the product.
3. Take or ship the product freight prepaid in the original container to an authorized ViewSonic service center or ViewSonic.
4. For additional information or the name of the nearest ViewSonic service center, contact ViewSonic.

Limitation of implied warranties:

There are no warranties, express or implied, which extend beyond the description contained herein including the implied warranty of merchantability and fitness for a particular purpose.

Exclusion of damages:

ViewSonic's liability is limited to the cost of repair or replacement of the product. ViewSonic shall not be liable for:

1. Damage to other property caused by any defects in the product, damages based upon inconvenience, loss of use of the product, loss of time, loss of profits, loss of business opportunity, loss of goodwill, interference with business relationships, or other commercial loss, even if advised of the possibility of such damages.
2. Any other damages, whether incidental, consequential or otherwise.
3. Any claim against the customer by any other party.

Effect of state law:

This warranty gives you specific legal rights, and you may also have other rights which vary from state to state. Some states do not allow limitations on implied warranties and/or do not allow the exclusion of incidental or consequential damages, so the above limitations and exclusions may not apply to you.

Sales outside the U.S.A. and Canada:

For warranty information and service on ViewSonic products sold outside of the U.S.A. and Canada, contact ViewSonic or your local ViewSonic dealer.

The warranty period for this product in mainland China (Hong Kong, Macao and Taiwan Excluded) is subject to the terms and conditions of the Maintenance Guarantee Card.



ViewSonic®