

ADA4 4-Channel Bi-directional Audio A/D and D/A Converter User Manual

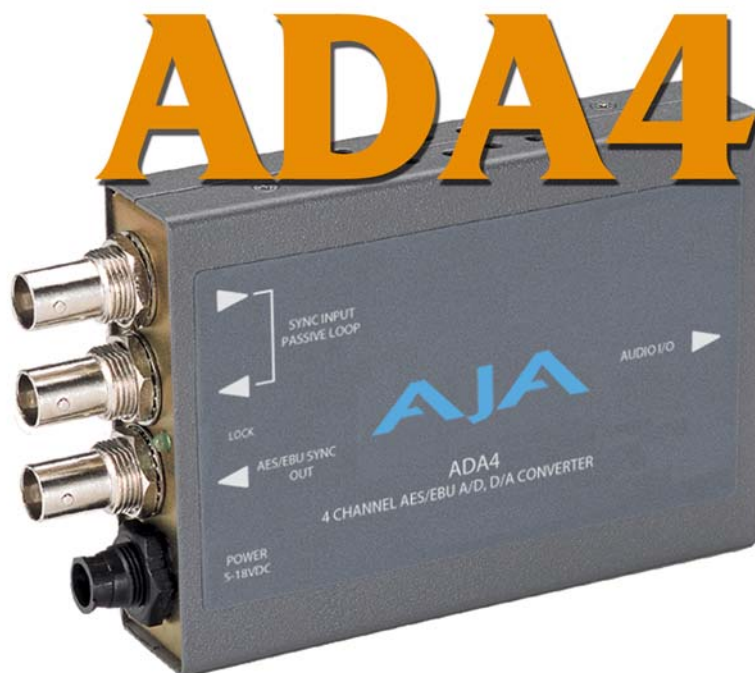

AJA
AJA VIDEO SYSTEMS INC

February 14, 2006 P/N 101662-00

Trademarks

AJA, Io, and Kona are trademarks of AJA Video, Inc. All other trademarks are the property of their respective holders.

Notice

Copyright © 2006 AJA Video, Inc. All rights reserved. All information in this manual is subject to change without notice. No part of the document may be reproduced or transmitted in any form, or by any means, electronic or mechanical, including photocopying or recording, without the express written permission of AJA Inc.

FCC Emission Information

This equipment has been tested and found to comply with the limits for a Class A digital device, pursuant to Part 15 of the FCC Rules. These limits are designed to provide reasonable protection against harmful interference when the equipment is operated in a commercial environment. This equipment generates, uses and can radiate radio frequency energy and, if not installed and used in accordance with the instruction manual, may cause harmful interference to radio communications. Operation of this equipment in a residential area is likely to cause harmful interference in which case the user will be required to correct the interference at his own expense. Changes or modifications not expressly approved by AJA Video can effect emission compliance and could void the user's authority to operate this equipment.

Contacting Support

To contact AJA Video for sales or support, use any of the following methods:

443 Crown Point Circle, Grass Valley, CA. 95945 USA

Telephone: +1.800.251.4224 or +1.530.274.2048

Fax: +1.530.274.9442

Web: <http://www.aja.com>

Support Email: support@aja.com

Sales Email: sales@aja.com

When calling for support, have all information on the product (serial number etc.) at hand prior to calling.

Limited Warranty

AJA Video warrants that this product will be free from defects in materials and workmanship for a period of five years from the date of purchase. If a product proves to be defective during this warranty period, AJA Video, at its option, will either repair the defective product without charge for parts and labor, or will provide a replacement in exchange for the defective product.

In order to obtain service under this warranty, you the Customer, must notify AJA Video of the defect before the expiration of the warranty period and make suitable arrangements for the performance of service. The Customer shall be responsible for packaging and shipping the defective product to a designated service center nominated by AJA Video, with shipping charges prepaid. AJA Video shall pay for the return of the product to the Customer if the shipment is to a location within the country in which the AJA Video service center is located. Customer shall be responsible for paying all shipping charges, insurance, duties, taxes, and any other charges for products returned to any other locations.

This warranty shall not apply to any defect, failure or damage caused by improper use or improper or inadequate maintenance and care. AJA Video shall not be obligated to furnish service under this warranty a) to repair damage resulting from attempts by personnel other than AJA Video representatives to install, repair or service the product, b) to repair damage resulting from improper use or connection to incompatible equipment, c) to repair any damage or malfunction caused by the use of non-AJA Video parts or supplies, or d) to service a product that has been modified or integrated with other products when the effect of such a modification or integration increases the time or difficulty of servicing the product.

THIS WARRANTY IS GIVEN BY AJA VIDEO IN LIEU OF ANY OTHER WARRANTIES, EXPRESS OR IMPLIED. AJA VIDEO AND ITS VENDORS DISCLAIM ANY IMPLIED WARRANTIES OF MERCHANTABILITY OR FITNESS FOR A PARTICULAR PURPOSE. AJA VIDEO'S RESPONSIBILITY TO REPAIR OR REPLACE DEFECTIVE PRODUCTS IS THE WHOLE AND EXCLUSIVE REMEDY PROVIDED TO THE CUSTOMER FOR ANY INDIRECT, SPECIAL, INCIDENTAL OR CONSEQUENTIAL DAMAGES IRRESPECTIVE OF WHETHER AJA VIDEO OR THE VENDOR HAS ADVANCE NOTICE OF THE POSSIBILITY OF SUCH DAMAGES.

Introduction

The ADA4 is a 4 channel converter which can be configured as a 4 channel A/D, a 4 channel D/A, or 2 channel A/D and 2 channel D/A. The ADA4 can accept a AES11, wordclock, or video sync/color black reference input for synchronization. Reference input and synchronization is automatic. Audio levels are configurable via dipswitch control.

Features

- Simultaneous A/D and D/A, or AES Synchronizer
- Full-time AES11 low jitter reference output
- Up to 4 channels of balanced analog to AES/EBU audio
- Up to 4 channels of AES/EBU to balanced analog audio
- Supplied XLR breakout cable
- AES11/Wordclock/Tri-level Sync/Color Black Reference Loop
- Adjustable Audio Levels
- Sample Rate Conversion Between 96KHz and 48KHz
- Dipswitch configuration
- 5-18VDC Power

Block Diagrams

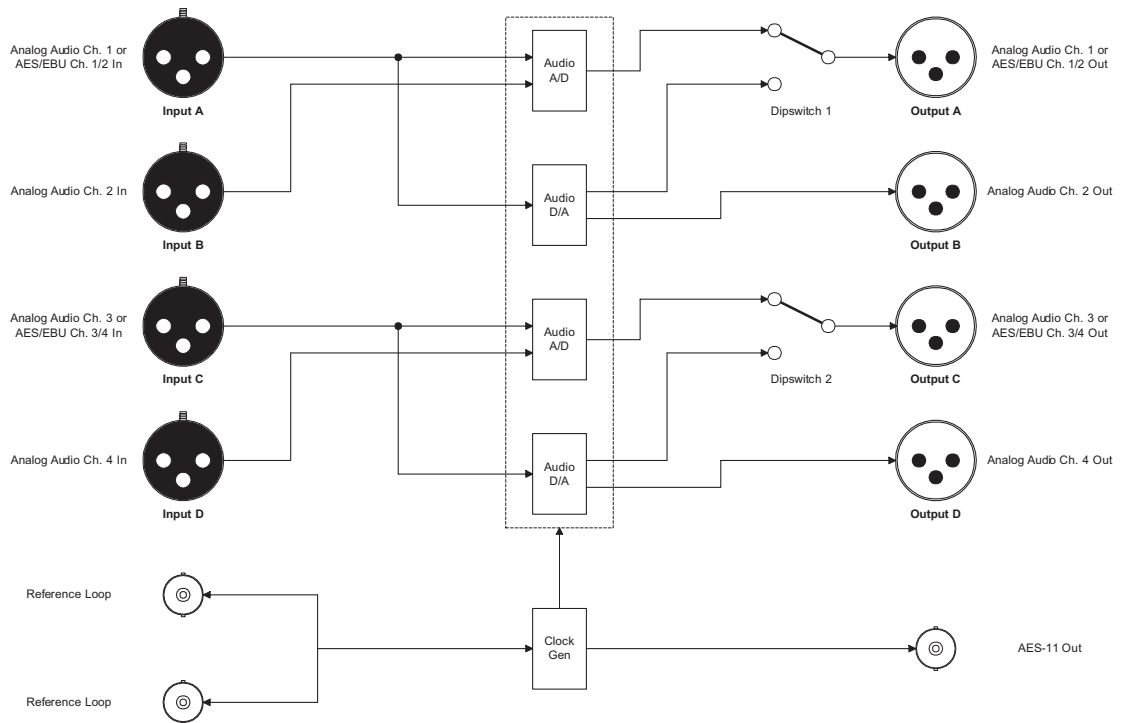

ADA4, Normal Mode Block Diagram (Jumper 2 Installed), A/D or D/A

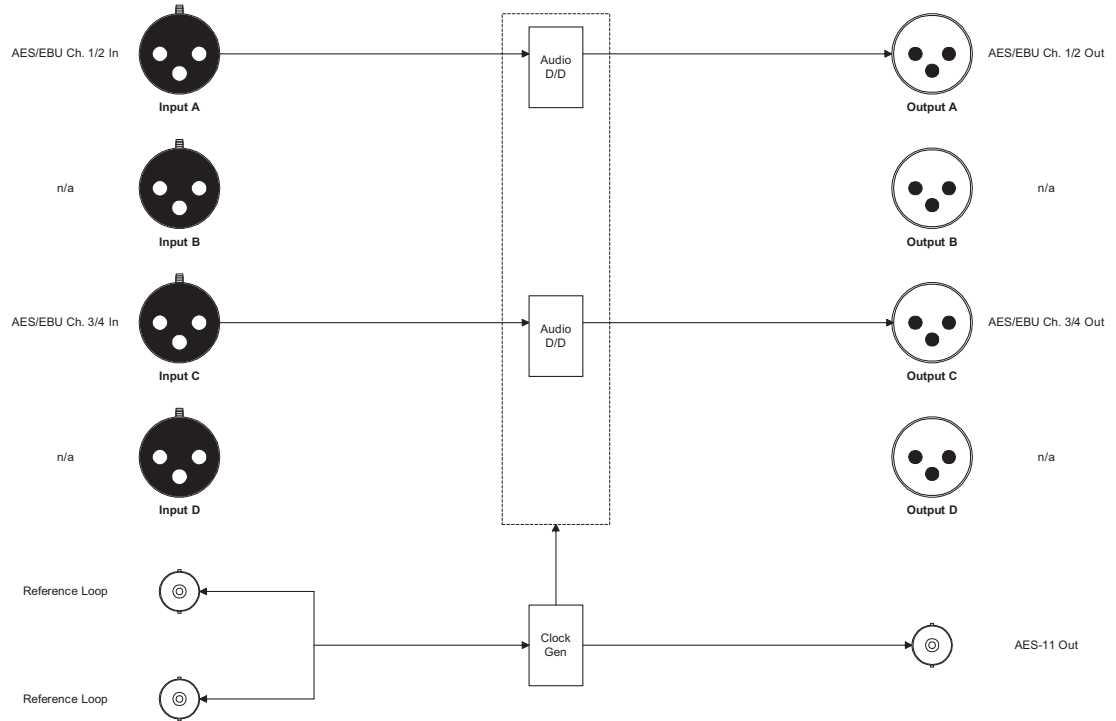

ADA4, Synchronizer Mode Block Diagram (Jumper 2 Removed), D/D

I/O Connections

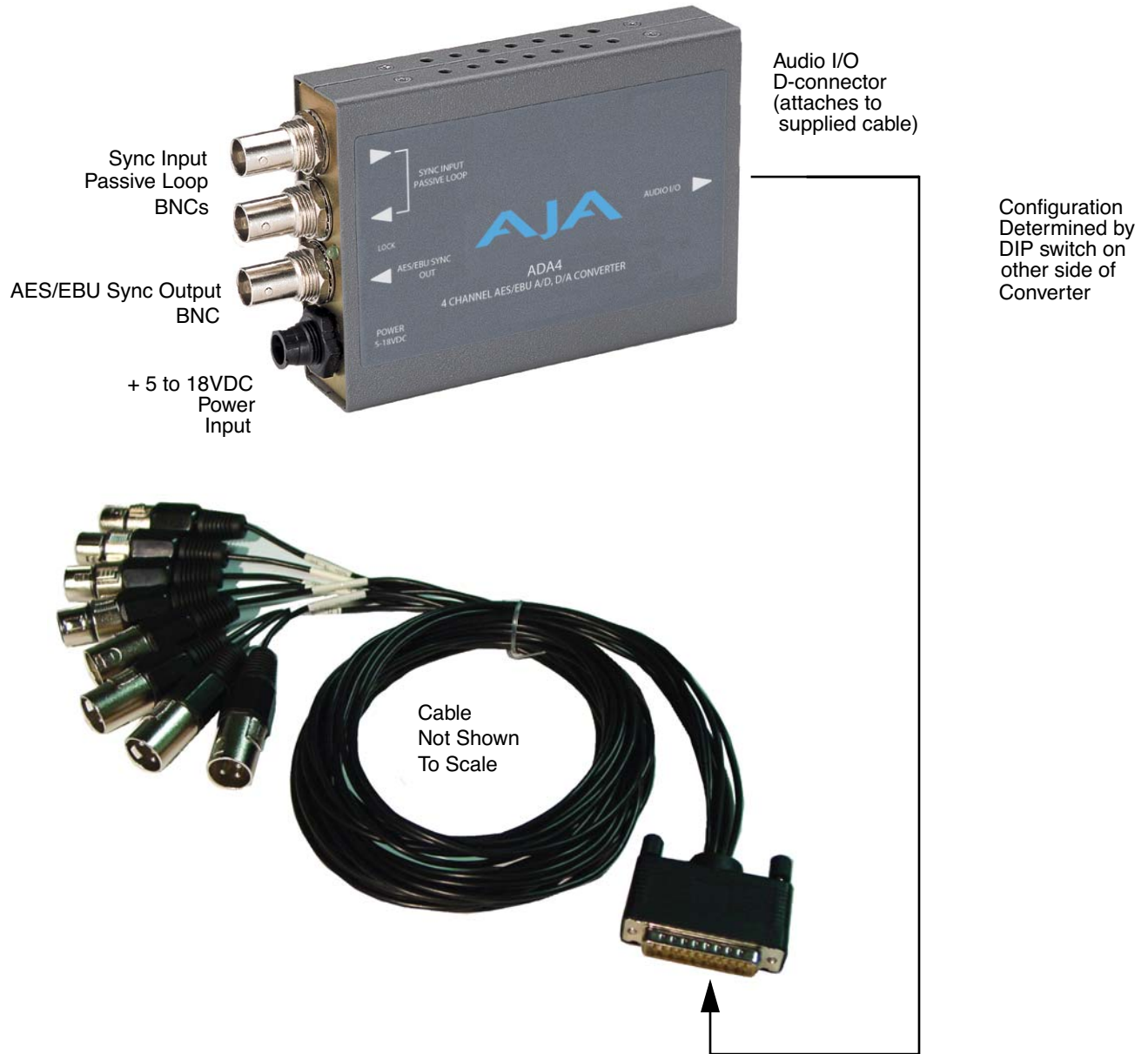

ADA4 and Cable, Side View

User Controls

The user interface for the ADA4 is a 4-switch DIP accessible through a cut-out in the bottom of the unit, and an internal 3-position jumper block accessed by removing the ADA4 cover (secured by 4 screws). Use the jumper to configure the mode of operation (*Normal* or *Synchronizer*). Then use the DIP switches—if necessary—to configure channels and audio levels.

The exact function of the jumper settings and each DIP switch are described on the following pages.

Factory default switch settings are all in the leftmost position.

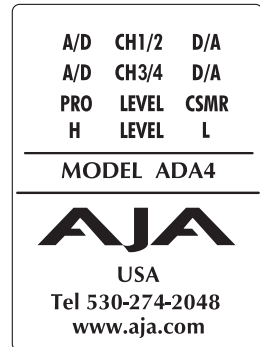
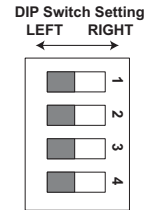

Normal Mode (Jumper #2 Installed)

Normal mode is the default operating mode of the ADA4 as shipped from the factory. In Normal mode, the ADA4 performs A/D or D/A audio conversion as configured by the 4 DIP switches. In the factory Normal configuration, the internal jumper #2 is installed and no jumper changes are required. DIP switch settings are discussed below:

Switch 1 (CH1/2: A/D or D/A)—Select type of conversion for channels 1 and 2

LEFT	RIGHT
Select Analog to Digital Conversion	Select Digital to Analog Conversion

Switch 2 (CH3/4: A/D or D/A)—Select type of conversion for channels 3 and 4

LEFT	RIGHT
Select Analog to Digital Conversion	Select Digital to Analog Conversion

Switch 3 (LEVEL)—Control whether audio levels are professional or consumer; affects all inputs and outputs

LEFT	RIGHT
Professional Level. +4 dBu is typical of most professional audio (See Output Level Selection Matrix Table)	Consumer Level. -10dBV (-7.8dBu) is typical of most consumer audio (See Output Level Selection Matrix Table)

Note: Professional audio equipment has much higher levels than consumer equipment: a 0 VU reading corresponds to +4 dBu. Connecting a professional +4 dBu device to a consumer audio input -10dBV (-7.8 dBu) may cause overloading, whereas the output of a consumer device probably does not have sufficient power to drive a professional audio input. With consumer and semi-professional audio equipment, a VU reading of 0 dB is typically referenced to -10 dBV. 0 dBu = 0.775 VRMS.

Switch 4 (LEVEL)—Control whether audio levels are high or low; affects all inputs

LEFT	RIGHT
High Level (See Output Level Selection Matrix Table)	Low Level (See Output Level Selection Matrix Table)

Output Level Selection Matrix For Switches 3 and 4

The following table shows the combinations of DIP switch settings required to configure the audio output levels shown.

Output Level	DIP Switch #3	DIP Switch #4
Audio Levels Pro-High: 0dBFS => +24dBu	LEFT	LEFT
Audio Levels Pro-Low: 0dBFS => +18dBu	LEFT	RIGHT
Audio Levels Consumer-High: 0dBFS => +12dBu	RIGHT	LEFT
Audio Levels Consumer-Low: 0dBFS => +6dBu	RIGHT	RIGHT

48 KHz/96KHz Output Mode (Jumper 1)

Jumper#1 selects how the AES outputs and the AES11 reference output run. If Jumper 1 is installed, they run in 48 KHz mode. If Jumper 1 is removed, they run in 96 KHz mode.

Synchronizer Mode (Jumper #2 Removed)

Synchronizer mode is an alternative operating mode where no audio A/D or D/A conversion takes place. Instead, it allows for an AES input to be sample rate converted and relocked to reveal an AES output that is low jitter, and—when a reference signal is applied—locked to reference. In this mode the DIP switches are ignored and all configuration options are set via a 3-position jumper located inside the ADA4 case. To access this jumper, remove the four phillips screws securing back side of the ADA4 case (the side having the DIP switch access hole in it). Once the case cover is removed, you can easily identify the jumper by its appearance. Jumper positions 1 through 3 are clearly marked on the circuit board next to the jumper. Refer to the following diagram for jumper settings and their meaning.

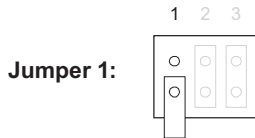

Example:
96kHz output mode selected
(jumper effectively removed).

Meaning:
Jumper 1 installed—48kHz: Any AES outputs and the AES-11 reference output are running in 48kHz mode.
Jumper 1 removed—96kHz: Any AES outputs and the AES-11 reference output are running in 96kHz mode.



Example:
Normal mode selected.

Meaning:
Jumper 2 installed—Normal Mode: Switches 1 and 2 independantly define A/D or D/A mode for their respective pair of channels. Switches 3 and 4 are used together to define the audio level.
Jumper 2 removed—Synchronizer Mode: Switches 1-4 have no effect. The ADA4 is in D/D mode, with the output re-timed to the reference signal, when applied. Without a reference signal applied, the ADA4 re-locks the output based on its stable free-running local oscillator.



Note:
Jumper 3 is not used, but is provided as a spare.

Meaning:
n/a: Jumper 3 is not used.

ADA4, Internal Jumper Settings

Jumper 3

Jumper#3 is currently unused.

Lock LED

An LED is located next to the BNC connectors which shows the type of signal locked (if any). Here are the meanings of the LED colors:

- Red = HD lock
- Green = SD lock
- Amber = AES-11 lock or Word Clock lock

Installation

Typically, ADA4 installation consists of the following:

1. disconnect +5VDC from the converter
2. configure the DIP switch for the desired equipment configuration
3. connect video equipment to the converter BNCs
4. apply +5VDC power to the converter (AJA power supply model DWP)

Specifications

Item	Specification
Analog Audio I/O	Balanced, XLR. One Channel per XLR connector.
AES Audio I/O	Balanced 110 ohm, XLR. Two Channels per XLR connector.
Analog Audio Levels (with Respect to Full Scale Digital)	+24dBu (SMPTE RP155), +18dBu (EBU R68), +10dBV (consumer +12.2 dBu)
Audio Converters	24 bit, 48/96 KHz
User Controls	External Dipswitch: Channel 1/2: A/D, D/A Channel 3/4: A/D, D/A Audio Level: Pro/Consumer Audio Level: High/Low
Size	5.8" x 3.1" x 1 (147 x 79 x 25mm)
Power	5-18V, 3 watts. Requires power supply.
Reference Loop	75 Ohm (unterminated). HD/SD Sync, AES-11, or Wordclock (48/96 KHz)

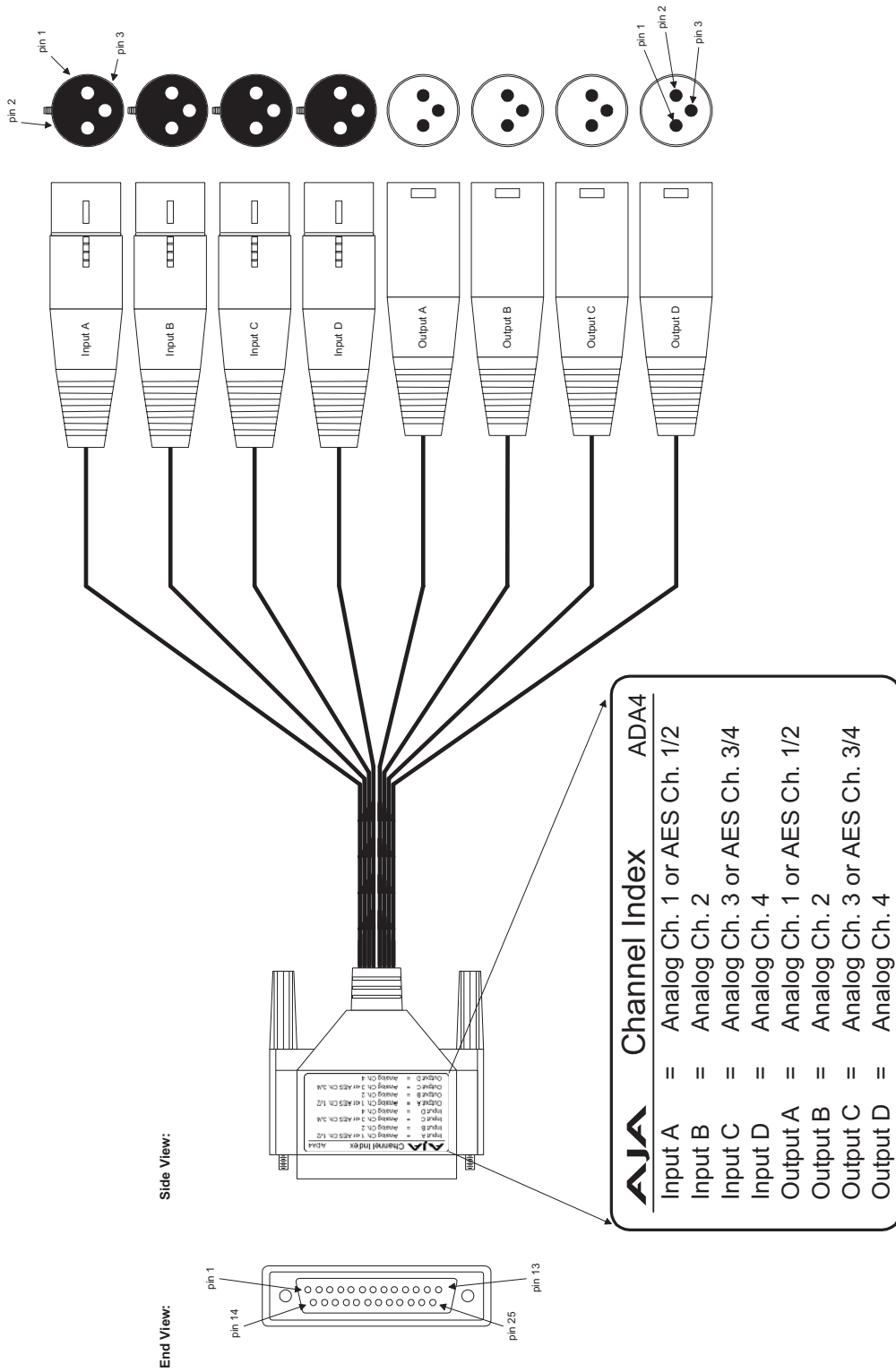

ADA4 Cable

